



superpower

SPHP 1000W Linear Voltage Regulator

Low Noise, Low Impedance,
Bootstrap Powered
100V, 10A Low Dropout Regulator

FEATURES

- Wide Vout range from 5V to 100V
- Maximum output current to 10A
- Up to 1000W to the load
- Very low noise
- Exceptionally fast transient response
- Very low output impedance
- Low drop-out voltage: only 3V at 10A
- Up to 97% efficient linear regulator
- Available as positive or negative output

APPLICATIONS

- Clean up SMPS output
- Music servers

DESCRIPTION

SPHP is a high performance voltage regulator with a novel circuit design (U.S. Patent 8,294,440) to internally power its reference circuit with its own regulated output. A floating reference allows output voltage from 5V to 100V with low noise, low output impedance, high current to 10A, and fast transient response in a compact circuit.

SPHP delivers current to a load with a clean dynamic waveform with minimum ringing or overshoot and settles quickly. With only two high impedance connections to input voltage, input ripple rejection is very high across a wide frequency band.

SPHP can be retrofit into existing systems or designed into new systems for maximum performance. A custom PCB design can be built into your own products.

[Contact Belleson](#) for more information.

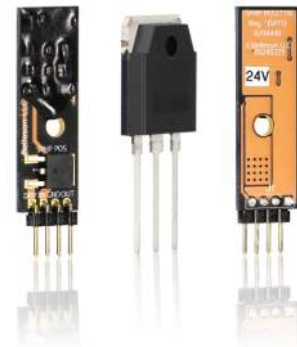
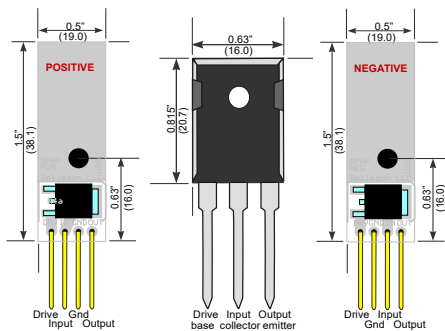

- Power amplifiers
- Turntable motors
- Any system that needs clean, quiet high power

Absolute Maximum Ratings

Parameter	Conditions	Value	Units
Input voltage maximum	Within power dissipation limits	120	V
Peak current	Within power dissipation limits	12.0	A
Total power dissipation	$T_A = 25^\circ\text{C}$ (requires heat sink) Derate above 25°C	200 1400	W $\text{mW}/^\circ\text{C}$
Thermal Resistance	Output transistor $R_{\theta JA}$, Junction-to-Ambient no heat sink	63	$^\circ\text{C}/\text{W}$

Operation at these limits is not guaranteed. Operation beyond these limits may result in irreversible damage.

SPHP Max. Load Current vs. (Vin-Vout)

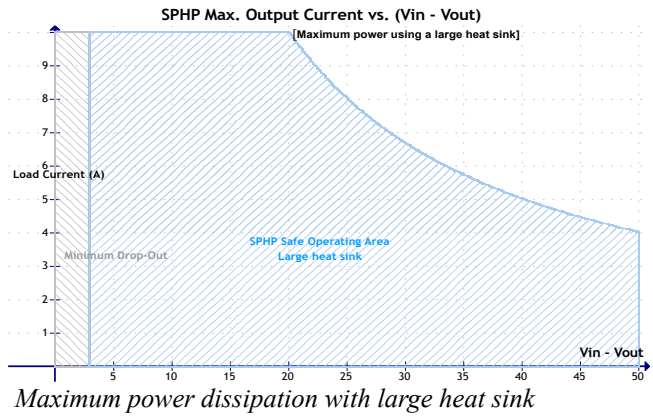
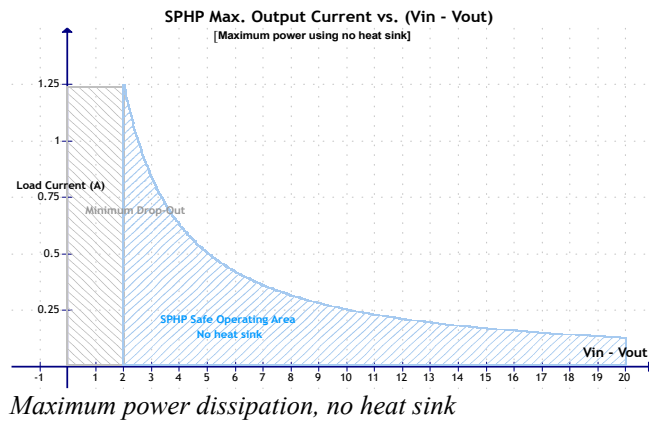

Typical Performance Characteristics

Unless otherwise noted, tests performed with output DC voltage=12V, DC load=240Ω (50mA), output capacitance=100μF

Parameter	Conditions	Value	Units
Input voltage maximum		120	V
Output voltage positive	Adjustable or fixed output	5 to 100 (1*)	V
Output voltage negative	Adjustable or fixed output	-5 to -100	V
Output Noise	RMS 20Hz – 20KHz	<1	PPM of Vout
Line Rejection	120Hz, 1Vpk	110	dB
Continuous current	Within power dissipation limits drop-out voltage 3V 5V	10 14	A
Maximum power dissipation (2*)	no heat sink sufficient heat sink	30 160	W
Drop-out voltage (typical)	load current 0 to 1.5A 2A to 4A 4A to 10A	2.0 2.5 3.0	V
Output Impedance	20Hz – 20KHz	50	mΩ

Notes

(*1) 3.3V fixed output is available by special order, see our web site

1A Step Response

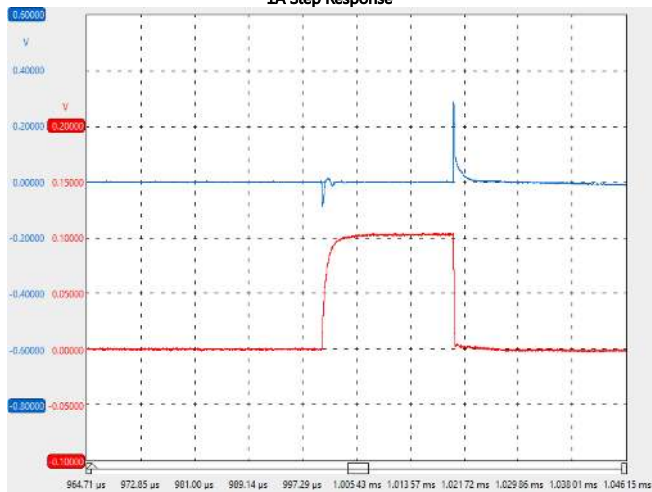

4A Step Response

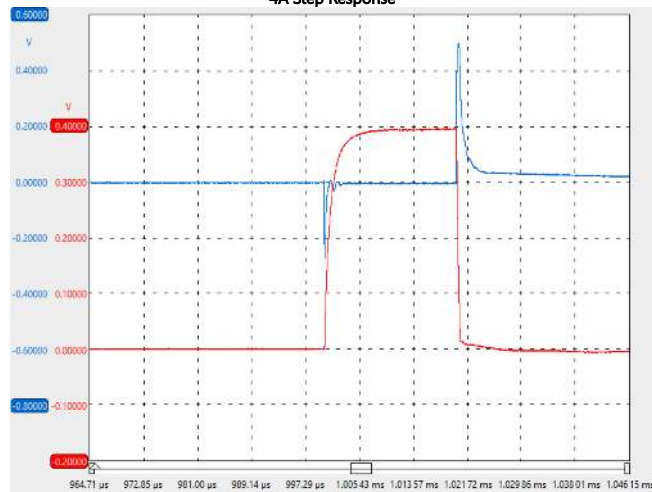

Output impedance vs. frequency

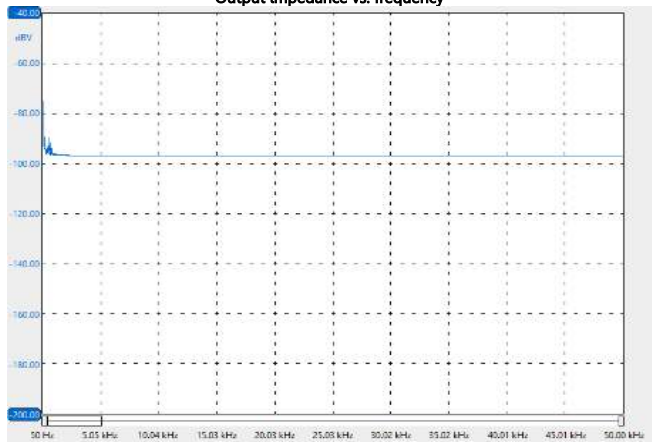

SPHP Ripple Rejection

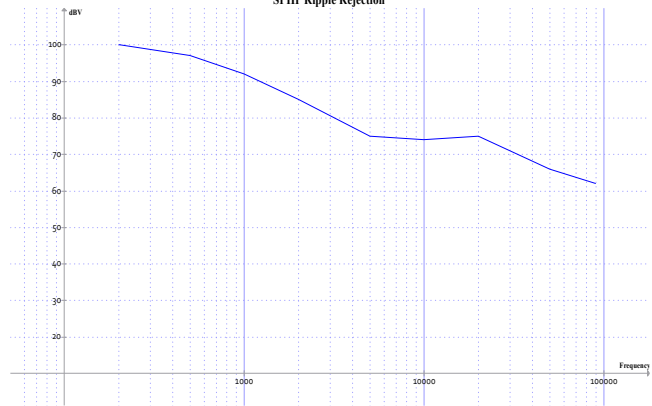

Application Information

Superpower provides a breakthrough combination of dynamics and low noise. This provides information to allow you to get the best use from your Superpower.

No Output Protection

To deliver maximum current with least drop out voltage, Superpower regulators have no output current limit. Any short circuit of the output to common may destroy the output device and/or control circuit.

Input Voltage Pre-regulation

Use of a pre-regulator may adversely affect dynamic response by limiting delivery of current. Best performance with input voltage directly from a power supply (linear or SMPS). If you use a pre-regulator, use another SPHP, that's what we have to use for testing.

Dynamics and Capacitance

Good dynamic response means supplying a lot of current very quickly. A large capacitor (100+ μ F) located near the input pins to provide reserve storage. An input capacitor also decreases output noise. See the discussion of **Line Rejection and Drop Out Voltage** on page 6 for minimum input capacitance requirements.

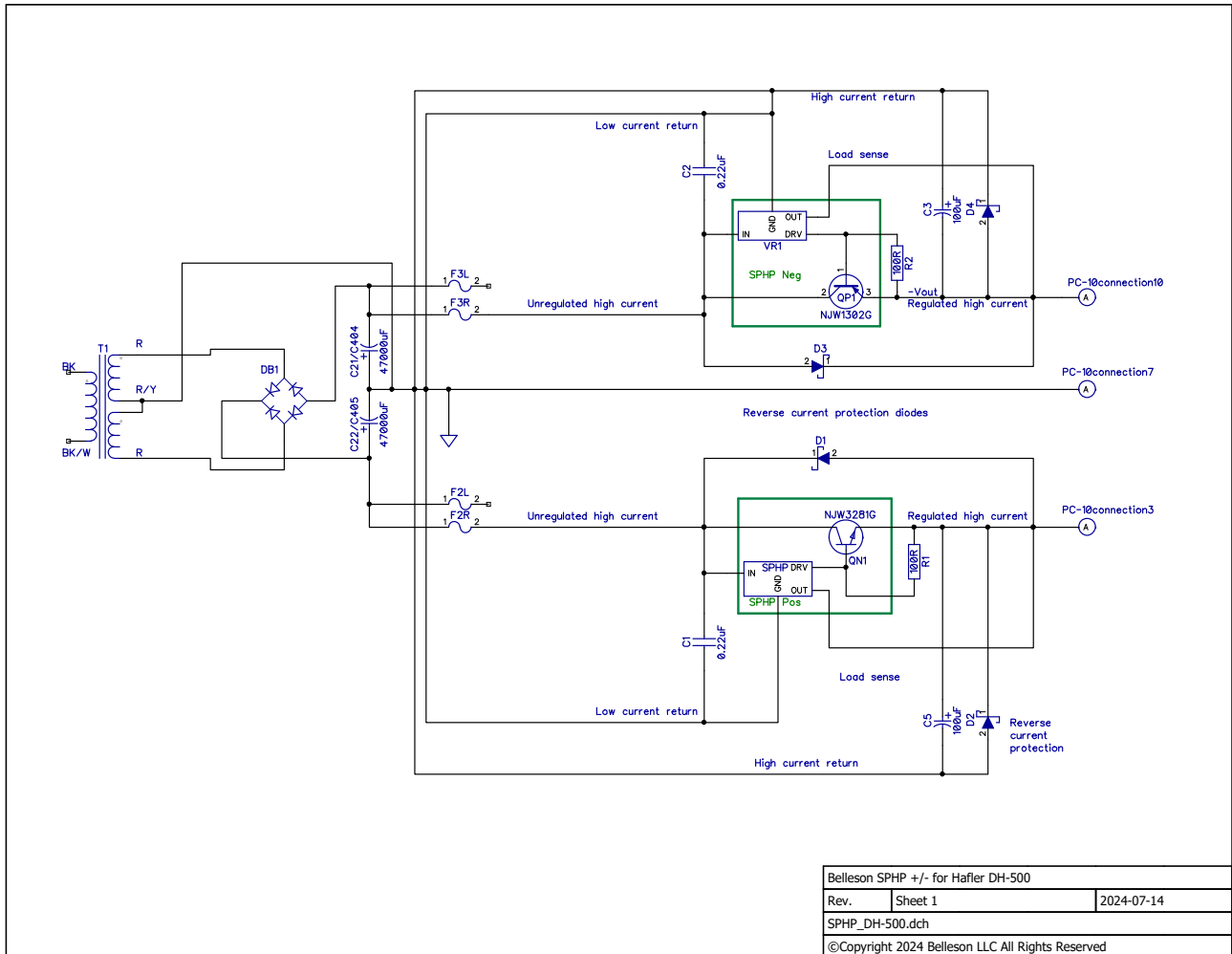

Figure 1: Typical regulated power supply for 500W stereo power amplifier (right channel shown)

If low level multi-MHz oscillation is observed at Vout, a 0.1µF or higher ceramic or film capacitor soldered directly across the IN to GND pins may cure it.

SPHP Sense Connection

SPHP sense is done via the OUT connection, see figure 2. Voltage at the load is connected from the power transistor emitter back to the regulator control PCB (light blue wire shown). This closes the SPHP control loop with a low current, low impedance path, while high current flows directly to and from the load via high current (red) wires.

Heat Sinks and Power Dissipation

This discussion pertains to the power dissipation in the regulator itself, not power delivered from a regulator to a load. This is calculated as

$$\frac{V_{in} - V_{out}}{I_{load} + 5mA}$$

SPHP can dissipate 1 or 2 Watts without heat sinking depending on ambient temperature and air flow. You can minimize regulator power dissipation by taking advantage of the low drop-out voltage, i. e. setting input voltage slightly higher than output voltage + drop-out.

To dissipate more than 2W, attach a heat sink or a heat conductive chassis. Use an insulating thermal pad or mica insulator with thermal paste and, for best results, electrically connect the heat sink to a stable, quiet ground point.

See (Vin-Vout) vs. Load Current curves on page 6 for more information.

Line Rejection and Drop Out Voltage

(This section does not apply when Vin is supplied by a switched mode power supply, only to a linear rectified power supply.)

As current increases, the minimum value of input ripple goes down and the regulator drop-out voltage goes up. If they meet or overlap, line regulation degrades rapidly because the regulator stops regulating when drop-out voltage is exceeded. Ripple on the output of a full wave rectifier is calculated as

$$V_r = \frac{Idc}{2fC}$$

where Vr is the peak to peak ripple voltage.

For example, consider a 5V regulator circuit as seen in Figure 1 using a 100µF filter capacitor. At 400mA, the ripple for a 60Hz AC input =

$$\frac{0.4}{2 \times 60 \times (100 \times 10^{-6})} = 33V (!)$$

Clearly 100µF is not enough capacitance for this circuit.

The same calculation with 4700µF results in a more tolerable 0.7V ripple. If the minimum point of the rectified voltage must be 5V, the DC + ripple at Cin must have a minimum low peak of 5.7V or higher to deliver 5V out.

To calculate the capacitance required for a given ripple voltage and output current, use

$$C = \frac{Idc}{2fV_r}$$

However, this does not consider the regulator drop out voltage—the voltage needed for the regulator. The minimum point of ripple must then be 5V Vout + Vdrop_{out} and Vin must peak at least 0.7V above that. So the absolute minimum voltage supplied by the rectifier at full load must be 7.7V(DC + ripple) to get 5V out and meet the specification for line regulation. It is best to allow for other factors and supply something higher than minimum, for example 9V for this circuit.

The required trade off is increased power dissipation in the regulator, which is

$$P_D = (V_{in} - V_{out}) \times I_{load} + (V_{out} \times 1mA)$$

The Belleson web site has both a heat sink calculator and a transformer calculator to help with selection of both of these. The transformer calculator also calculates peak ripple voltage for a given filter capacitor size. They are found on a tab of the [SPHP description page](#).

Reverse current protection diodes

A regulated supply often has large capacitors full of charge. When input power is shut off, the charge in those caps must dissipate somewhere. We don't want all those electrons to go back through the regulator, because that can damage the circuit. D1,D2,D3,D4 in figure 1 and the two diodes in figure 2 are reverse biased when the regulator is powered. When power is removed, they shunt current from discharging load

capacitors away from the regulator. Figure 1 stipulates Schottky diodes because their lower forward conduction voltage drop (compared to silicon junction diodes internal to the regulator) gives better protection. *These diodes are very important and should be added to any SPHP circuit.* SPHP has some internal protection, but those small SMD diodes may degrade over multiple off/on cycles, thus the addition of external power diodes is needed.

SPHP has no built-in stabilizing capacitor, so an external one must be connected from V_{OUT} to ground as shown here. This should be $100\mu\text{F}$ or more and have a voltage rating higher than V_{OUT} .

The power transistor supplied with SPHP is NJW3281G (positive) and NJW1302G (negative), 250V, 15A, 250W bipolar transistors.

High Current and Physical Design

With a linear power supply SPHP regulator, power transformer, bridge rectifier, large filter capacitor (TRF), how do we connect them? Two important factors in wiring an accurate high current power supply are wiring resistance and stability. At 10A, $10\text{m}\Omega$ equates to a 0.1V drop. As current changes through an impedance, it will modulate the voltage at the load, so even with a perfect voltage source, a changing high current load can modulate the voltage at the load due to wiring resistance.

SPHP is designed with a small PCB controller and a separate high current output transistor (QN1 in the schematic). This allows the control loop to be independently placed and wired with a maximum current of about 250mA, and QN1 can be separately heat sink mounted with large currents flowing separately through it.

Figure 2 shows physical wiring of the above schematic with matching wire colors. Notice the red path of high current from the raw supply to the power transistor to the load and back to the raw supply. Make this path short, from heavy gauge copper trace or wire. The black and green DRV current paths can be smaller, they will have approximately 250mA at full 10A regulator current. The other paths are very low current.

Two external protection diodes allow stored charge from large capacitance to by-pass the regulator at power-down if input voltage falls faster than output voltage or if V_{OUT} gets pulled below ground by some load related condition (e.g. an inductive load). Even though SPHP has internal protection diodes, larger external ones such as 1N4004 are recommended.

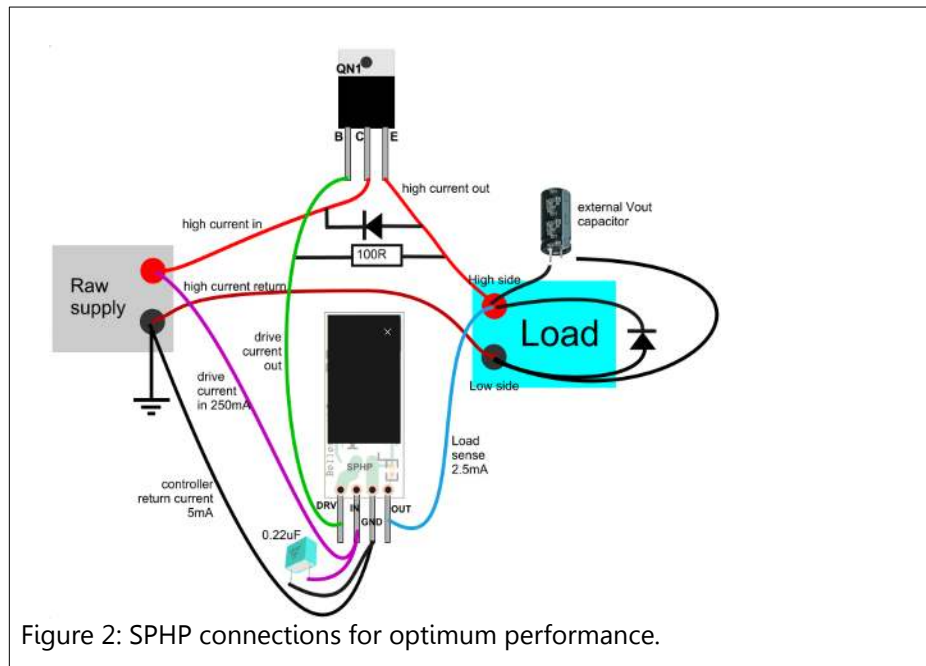

Figure 2: SPHP connections for optimum performance.

More SPHP usage details

SPHP is a high voltage, high current regulator shipped in two pieces, a controller circuit and a power output transistor. Together they are capable of providing up to 1000W of power, 100V at 10A, to a load. V_{out} is available from 5V to 100V, or 3.3V via special order. The power transistor (NJW3281G or NJW1302G) is rated to 250W with adequate heat sink. At 10A we recommend V_{in} 4V to 6V higher than V_{out} to keep power dissipation low in the power transistor. See [our web site](#) for a detailed discussion of regulator drop-out.

The circuit is designed so all load current flows through the power transistor and not through the controller. This removes IR losses and thermal transients from the controller circuit and allows for better regulation.

Care must be used in designing high current circuits, where PC traces are short and wide enough for delivering large currents with low resistance and inductance.

Notice in figure 2 the high current path: bridge->QN1 collector->QN1 emitter->Load->bridge. Use heavy PCB traces for this connection path. The maximum current in the control PCB is QN1 base current from DRV which has a maximum of about 250mA for output current of 10A.

Also notice the "OUT" pin of the SPHP—with the output transistor mounted off-board, this is not really OUT, it is the output *sense* for the regulator control loop. It's a low current line (about 1mA) that should be connected near the load. It is a low impedance node so it's not highly susceptible to EMI contamination.

SPHP can deliver up to 10A at 100V. This is enough for most power amplifiers and to clean the output of noisy and slow switched mode power supplies in music servers, audio consoles, motor drivers and more. High current circuit design requires careful thought about power dissipation, where current flows and other important topics. We'll discuss this diagram of a basic power supply using SPHP:

. To start, let's define some terms:

V_{IN}	Input voltage to regulator
V_{OUT}	Voltage regulator output
V_{DO}	Regulator drop-out voltage: minimum (V_{IN} -

	V_{OUT}) to keep regulation
I_L	Load current from regulator output to its load and back to power source (typically a transformer+rectifier+filter)
P_L	Load dissipation: V_{OUT} / I_L
P_R	Regulator dissipation: $(V_{IN} - V_{OUT}) / I_L$
LDO	Low Drop Out
V_{RIP}	Input Ripple, the AC change at V_{IN}

Power Dissipation—Regulator vs. Load

SPHP can provide up to 1000W to a *load* while the regulator can dissipate 200W. Total power dissipation for this "worst case" situation is thus 1200W. You must [choose a power transformer with high enough VA to supply the total power](#).

Any power used by the regulator is not delivered to the load and is considered wasted. Given regulator power dissipation = drop-out voltage times load current, it's easy to see why low drop-out voltage is important, and why LDO is a standard acronym in regulator data sheets. The closer V_{IN} is to V_{OUT} , the less power is wasted.

Drop-Out Voltage and Supply Efficiency

SPHP drop-out, as for most linear regulators, increases with load current to a maximum of 3V at 10A. Thus it is theoretically possible to make a 1000 Watt power supply with 30W of wasted power, giving an efficiency of 97%. Practically speaking, however, an efficiency of 80% is considered great for a high power linear supply. *Why is this?*

Looking at the above schematic, AC current is rectified by bridge rectifier BR1 and filtered (smoothed) by capacitor C1. After mains power is applied, C1 charges to its peak DC value and will remain charged until current is requested by the load. Realize that C1 only charges when the peak voltage from BR1 goes above C1 voltage so for much of the AC cycle, C1 can supply current but not receive it.

Input Ripple Voltage and Regulation

While C1 is supplying current and bridge voltage is below C1 voltage, C1 discharges. There is a long time (relative to a power line cycle) when C1 discharges and

a short time when it recharges. This is what makes the familiar saw tooth voltage ripple at the input to the regulator.

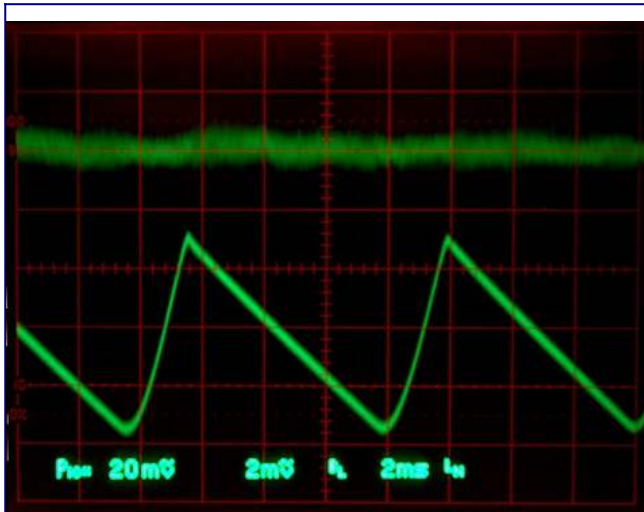

Figure 3: Bottom trace: ripple from transformer-rectifier-filter chain at regulator input
Top trace: regulator output showing ripple removal

As you know, $i=Cdv/dt$ and higher load current discharges $C1$ more quickly. If $C1$ discharges enough during an AC power line cycle to go below $(V_{OUT}+V_{DO})$, the **regulator stops regulating!**

Input Capacitance and Drop Out Voltage

Look again at $i=Cdv/dt$. Rearranging terms gives $dv=idt/C$ to show that ripple is reduced by increasing C . Now rearrange again and substitute frequency $f=1/dt$ to get an equation for $C1$ given load current and maximum desired ripple: $C=i/(2fdv)$. The factor of 2 is because BR1 is a full wave rectifier and C charges twice per cycle. A half wave rectifier does not have this factor.

For 10A load and 1V maximum ripple at a 50Hz power line cycle (worst case, also makes the math prettier), and 1V maximum ripple target, the required $C1=10/100$, or 100000 μ F. The 47000 μ F value assigned to $C1$ in the above schematic will allow about 2.5V maximum ripple voltage.

Given that the *minimum* ripple voltage must stay above $V_{OUT}+V_{DO}$, the voltage at BR1 must go above $V_{OUT}+V_{DO}+V_{RIP}$ to keep $C1$ charged enough to allow the regulator to function correctly. For a 12V regulator, BR1 voltage must stay above $12+3+2.5=17.5V$ using $C1=47000\mu$ F. This explains why a supply efficiency of 97% is unrealistic. For this 12V regulator, efficiency is

$100 \times 12 / 17.5 = 69\%$. Even with $C1=100000\mu$ F, efficiency goes to 75% which wastes 1/4 of the input power. Ripple depends only on load current, so given the same load and V_{DO} , a higher V_{OUT} supply will be more efficient than a lower V_{OUT} supply.

General Conclusions

- Power dissipation by the regulator is linear as $(V_{in}-V_{out}) \times (\text{load current})$
- $(V_{in} - V_{out})$ is RMS voltage
- If V_{in} is fed from a rectifier+filter cap, V_{in} is not DC but has ripple
- Ripple has a linear dependence on load current as $dv=i/(2fC)$ where dv = ripple amplitude, i =RMS load current, f = power line frequency and C =filter capacitance
- Minimum peak of ripple must not go below $(V_{out} + V_{dropout})$, otherwise regulator stops regulating

From these we conclude:

- Larger filter capacitance = lower ripple
- Lower ripple allows lower V_{in}
- Lower V_{in} allows lower regulator power dissipation

More Overhead

For the chosen 12V supply, the transformer must keep V_{IN} above 17.5V to maintain regulation. With high current demand, transformer secondary voltage tends to sag (decrease). The peak unloaded voltage of the transformer must be increased to account for sag, and also to account for the worst case low primary voltage. Ultimately this transformer must have a 20V to 24V peak output voltage due to these multiple system constraints.

Regulation of SMPS

A switched mode power supply can make a much more efficient raw power source than a transformer/rectifier/filter (TRF) source. This is not only because the SMPS is efficient, it's also because the maximum ripple from the SMPS is typically less than 1V even at high currents. Thus the additional "overhead" drop-out voltage needed by a linear regulator is much lower. So for the 12V example given,

the raw input voltage can be 15V instead of 17.5V, taking efficiency up to 75% to 80%.

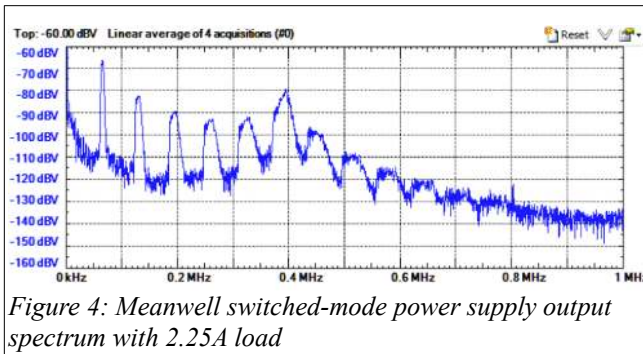

Figure 4: Meanwell switched-mode power supply output spectrum with 2.25A load

SPHP's high ripple rejection across a wide bandwidth make it an ideal choice for SMPS regulation, because SMPS tend to have smaller amplitude ripple at much higher frequencies.

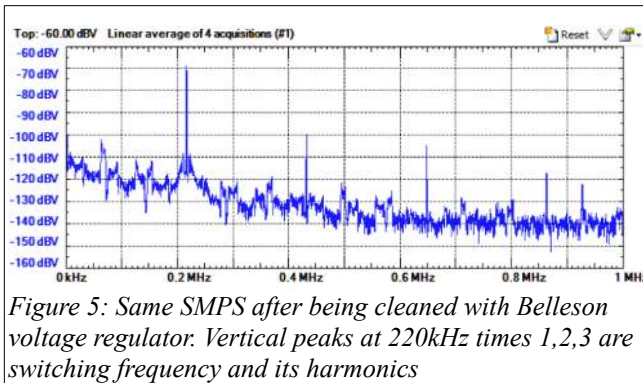

Figure 5: Same SMPS after being cleaned with Belleson voltage regulator. Vertical peaks at 220kHz times 1,2,3 are switching frequency and its harmonics

A SMPS can also be powered from most international line voltages from 100V to 250V. A combination SMPS with SPHP regulator can deliver clean high power at high efficiency.

Caveats

As you know, SPHP is a high power voltage regulator. To quote Spiderman's Uncle Ben (who was quoting Sir Winston Churchill), "With great power comes great responsibility." Please note the following and be careful during design and testing of your power supply:

- Use extreme caution with high voltage circuits, this circuit can deliver lethal voltage and current. Keep one hand in your pocket!
- There is no internal limit on output current. With 10+ amps, SPHP is unforgiving of mistakes and is quickly destroyed by an output short circuit or other incidents. If possible, use an inexpensive monolithic substitute for new product design, then replace with SPHP when design is fully functional. The IN/GND/OUT pins on positive

SPHP controller and GND/IN/OUT on negative SPHP match LM78xx and LM79xx pin connections for temporary substitution.

- Output voltage is factory adjusted to 12V during testing. If your system is designed for high voltage V_{out} and thus has high input voltage, adjust SPHP to the desired output voltage under NO LOAD. In other words, if you power up SPHP under load with 12V output but $V_{in} = 80V$ (for example) and load current = 5A, that puts the regulator output transistor under 340W load until V_{out} is adjusted to its correct value. This will destroy the output transistor and probably the regulator controller.
- V_{out} adjustment is reverse of convention—clockwise decreases V_{out} , counter-clockwise increases V_{out} .
- For best transient response, place a 100Ω resistor between base and emitter of the output power transistor.
- For best stability across all load current, place a 0.2μF polypropylene capacitor from V_{in} to GND pins near the regulator PCB.
- SPHP has two internal protection diodes, however they are small SMD devices. If your application has large capacitance at regulator input and output, two external high current protection diodes (e.g. 1N4007) from [V_{out} to V_{in}] and [GND to V_{out}], [given anode to cathode], will improve long term reliability.

Mechanical Specifications

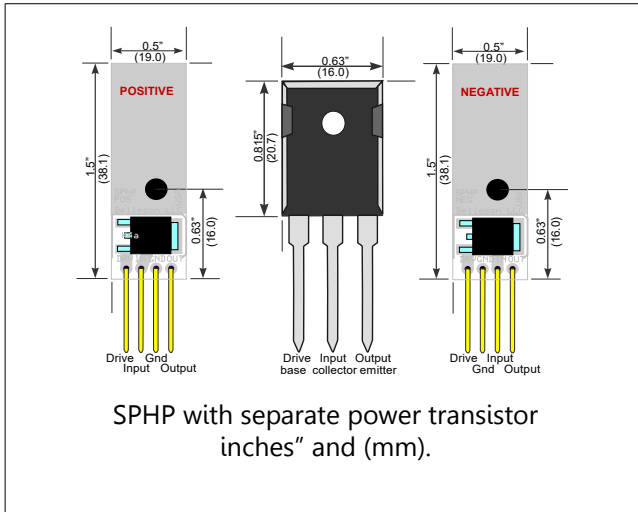

External dimensions may vary by $\pm 2\%$, mounting hole dimensions by $\pm 0.5\%$.

Legal Information

By using Belleson voltage regulators, you agree that SPHP have no output protection and a short circuit of the output to ground can damage or destroy the regulator. All devices are tested prior to shipment and damaged devices will not be replaced.

You also agree that use, misuse or misapplication of Belleson products may cause damage to associated equipment and you as user of the product(s) accept all responsibility for all consequences of use or application of Belleson product(s) and will not hold Belleson responsible for any equipment damage nor personal injury as a result of use or attempted use of Belleson products.

Belleson products are not authorized for use as critical components in life support devices or systems. as used herein:
Life support devices or systems are devices or systems which

- (a) are intended for surgical implant into the body, or
- (b) support or sustain life, and whose failure to perform when properly used in accordance with instructions for use provided in the labeling, can be reasonably expected to result in a significant injury to the user.

A critical component is any component of a life support device or system whose failure to perform can be reasonably expected to cause the failure of the life support device or system, or to affect its safety or effectiveness.

Copyright © Belleson LLC, all rights reserved.

